

DEĞİRMEN GRUBU

MILLING GROUP



ÜRÜN KATALOĞU
PRODUCT CATALOGUE
www.mucit.com



mucit[®]
Plastik & Kalıp



| KURUMSAL

Mucit Plastik ve Kalıp 1995 yılında Mucit Yiğit önderliğinde kurulmuştur. Kalıp tasarım-üretim ve plastik enjeksiyon sektöründe faaliyet göstermekte olup ayrıca birçok farklı sektör için çözüm ortağı olmuştur.

Kuruluşumuz plastik ve kalıp sektörlerindeki üretim ağını arttırarak savunma sanayi, traktör yedek parça, değirmen yedek parça, tarım makineleri yedek parça, otomotiv yedek parça, gıda makineleri yedek parça gibi sektörlerde de geniş ürün yelpazesıyla müşteri talepleri doğrultusunda inovatif ve efektif hizmetler vermektedir.

Firmamız cnc torna, cnc dik ve yatay işleme, cnc double kolon, tersine mühendislik, prototip modelleme, lazer kesim, lazer kaynak, kaynak robotları, plazma oksijen kesim, hidrolik - eksantrik pres ve plastik - kauçuk enjeksiyon makine parkurumuzla ve yüze yakın kalifiyeli personelimize üretim faaliyetlerini gerçekleştirmektedir.



| VİZYONUMUZ

Üretim yeteneğimiz, engin tecrübemiz ve ileri teknolojimiz ile yenilikçi çözümler üreterek, Savunma Sanayi başta olmak üzere çeşitli sektörlerde üretim kapasitemizi ve satış hacmimizi arttırmak, yurt içi ve yurt dışı pazarlarında değer yaratmaktır.

| MİSYONUMUZ

Huzurlu çalışma ortamında müşterilerimizin ihtiyaç ve beklentileri doğrultusunda kaynaklarımızı etkin ve verimli kullanarak sürdürülebilir üretimi sağlamak, ülke ekonomisine ve toplumun kalkınmasına katkıda bulunmaktır.

| KALİTE POLİTİKAMIZ

Profesyonel sistemler ile sürdürülebilir kalite anlayışı ve müşteri memnuniyeti ilke edinilerek üretim faaliyetlerimizi sürdürmekteyiz. En kaliteli ürün/hizmeti zamanında sunmak ve kalitemizi sürekli geliştirmek adına 05.09.2006 tarihinde ISO 9001:2000 Kalite Belgesi alınmıştır.



Kalite ve Güvenle
27 Yıldır
Şekil Verdik
Plastiğe





10.000M2 ÜRETİM ALANI

Üretim bölümümüzde 100-1600 aralığında tonaja sahip ileri teknoloji ile donatılmış, toplamda 20 adet plastik enjeksiyon makinesi mevcuttur.

2000'den FAZLA ÜRÜN

Sektördeki birçok firma için kalıp ve ürün tasarımı yapan Mucit Plastik ve Kalıp Tarım, Gıda, Değirmen gibi birçok sektörde üretim faaliyetlerine devam etmektedir.

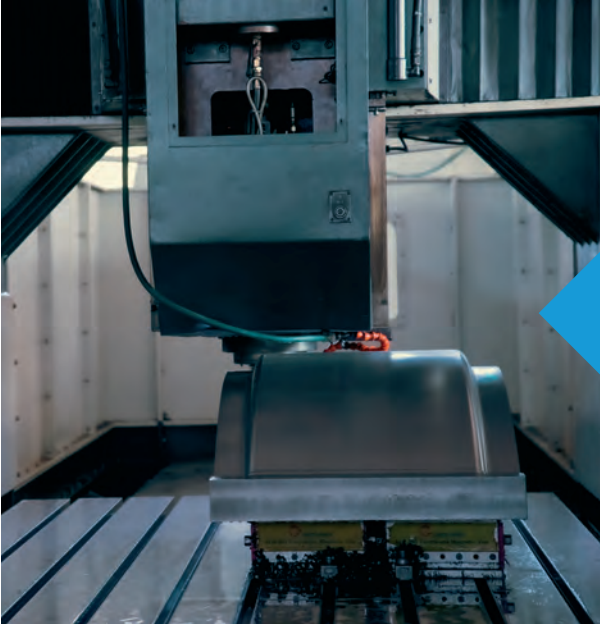

PROFESYONEL KALIPLAMA ATÖLYESİ

Yüksek teknolojiye sahip Mucit Plastik Kalıphane Bölümü'nde plastik enjeksiyon kalıp imalatı yapılmaktadır.

INDEX

ELEVATÖR KOVASI	01-06
KONVEYÖR PALET	07-10
DEĞİRMEN GÖSTERGE CAMI	11-12
BAĞLANTI ELEMANLARI	13-15
TUTMA-ÇEVİRME KOLLARI	16-18
TAPETEN	19-20
DEĞİRMEN MAKİNALARI EKİPMANLARI	21-24



ELEVATÖR **KOVASI**

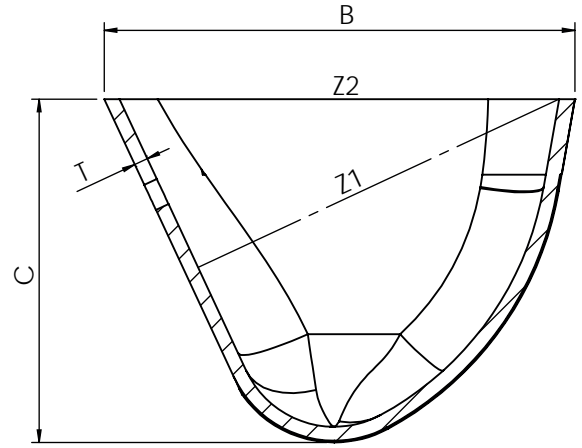
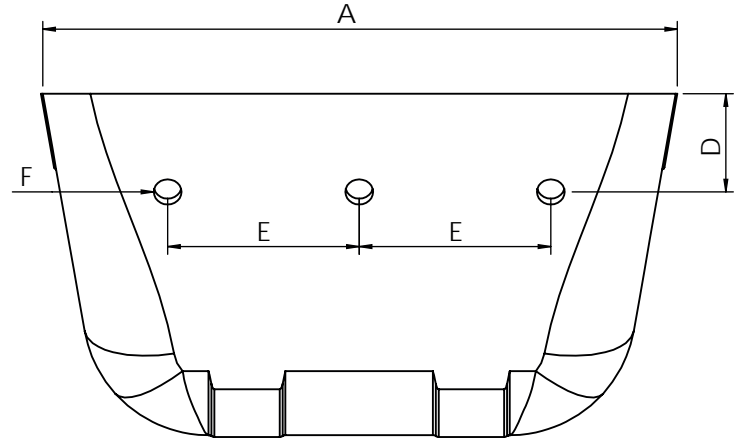
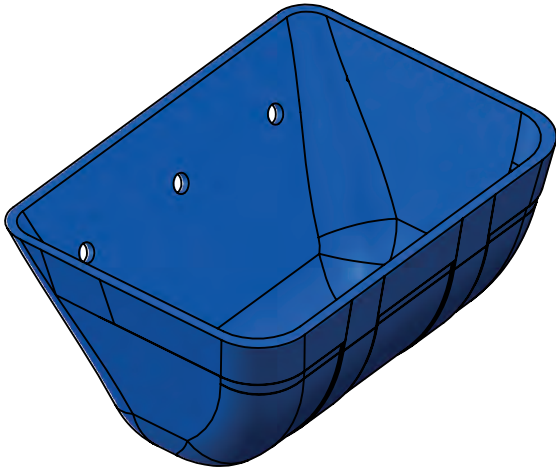

KOD	NOMİNAL ÖLÇÜ (MM)	A	B	C	T	D	E	F	Delik Sayısı	Z1	Z2
MCT10084	90x90	96	96	70	3	20	45	8	2	0,19	0,32
MCT10085	100x90	106	96	75	3	22	50	8	2	0,23	0,38
MCT10086	120x100	128	108	90	4	30	60	8	2	0,368	0,586
MCT10087	140x120	147	127	95	3,5	32	70	8	2	0,544	0,906
MCT10088	160x140	168	148	100	4	33	90	8	2	0,74	1,31
MCT10089	180x140	188	148	105	4	40	110	8	2	0,95	1,6
MCT10090	200x150	208	158	120	4	42	130	8	2	1,31	2,13
MCT10091	230x170	230	170	125	5	39	70	8	3	1,6	2,6
MCT10092	250x185	251	185	135	5,5	39	80	8	3	2,03	3,37
MCT10169	260x220	260	221	145	6	68	80	12	3	4	5
MCT10183	280x195	280	197	160	6	35	95	10	3	4,2	5,17
MCT10093	300x225	296	227	175	9	45	100	8	3	4	6,4
MCT10120	320x220	320	220	150	6	47	97	10	3	3,4	5,86
MCT10175	340x240	341	240	175	8	50	120	10	3	6	8
MCT10125	400x230	406	229	160	8	62	67	9	5	5,48	7,76

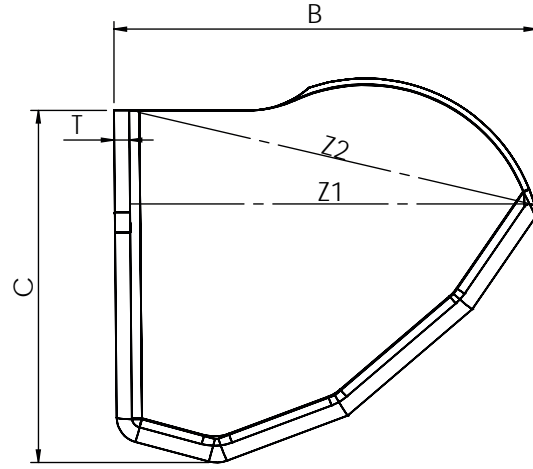
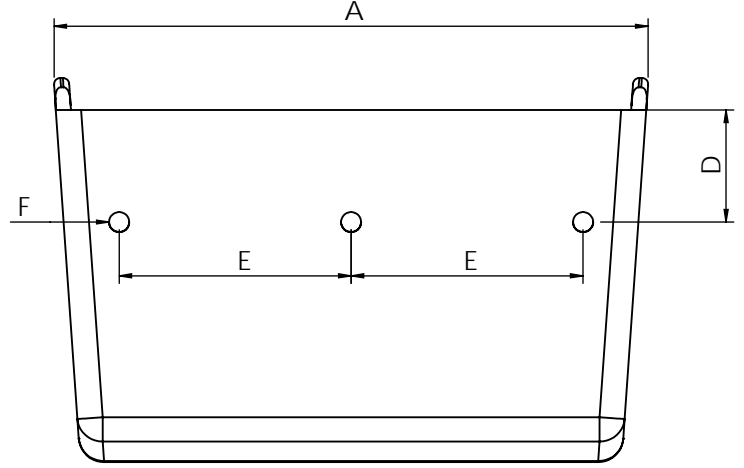
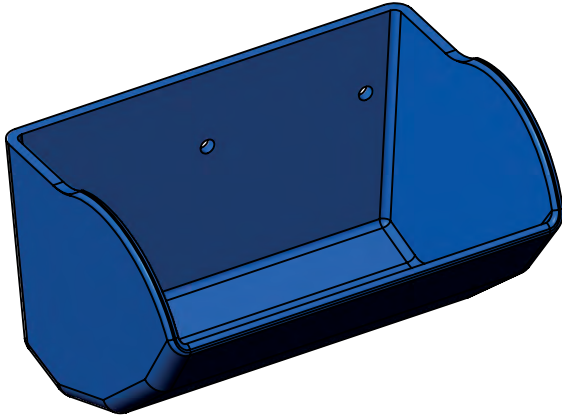

KOD	NOMİNAL ÖLÇÜ (İNÇ-MM)	A	B	C	T	D	E	F	Delik Sayısı	Z1	Z2
MCT10181	6"x4" 160x120	160	120	105	6	35	70	8	2	0,93	1
MCT10182	7"x4,5" 180x120	180	120	115	6	45	63	8	3	1,15	1,28
MCT10124	8"x5" 200x140	200	140	130	6	*	*	*	*	1,275	1,6
MCT10179	8"x6" 210x170	208	169	155	6,5	44	78	8	3	2,2	2,65
MCT10180	9"x5" 230x140	230	140	130	6	45	92	8	3	1,95	2,2
MCT10094	9"x6" 235x170	235	168	152	8	44,5	92	8	3	2,2	2,87
MCT10174	10"x8" 255x205	254	203	203	6	55	77	8	3	3,7	4,35
MCT10095	11"x6" 290x170	287	168	153	9	44,5	76	10	4	2,74	3,56
MCT10096	12"x8" 315x220	316	220	230	8	58	85	9	4	5,23	7,23
MCT10119	13"x8" 350x215	350	214	222	6,5	40	55	10	5	6,71	8,08
MCT10097	14"x7" 365x165	365	165	155	6	35	90	10	4	3,2	4,2
MCT10172	14"x8" 350x205	346	203	190	8	*	55	9	5	5,82	6,55
MCT10118	16"x9" 420x225	419	225	223	10	55	72	9	6	7,2	9,62
MCT10104	20"x8" 520x225	520	224	221	10	57	80	8	6	9,3	12,3
MCT10177	20"x8" 520x215	520	215	170	10	55	80	8	6	7,32	8,75

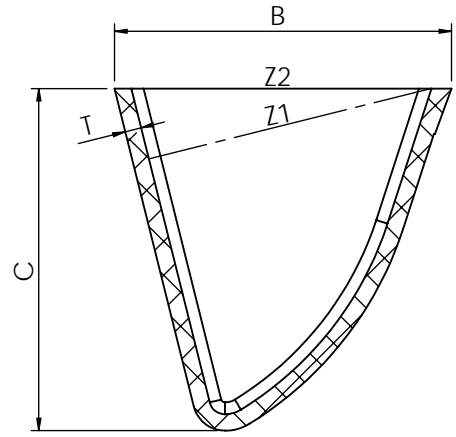
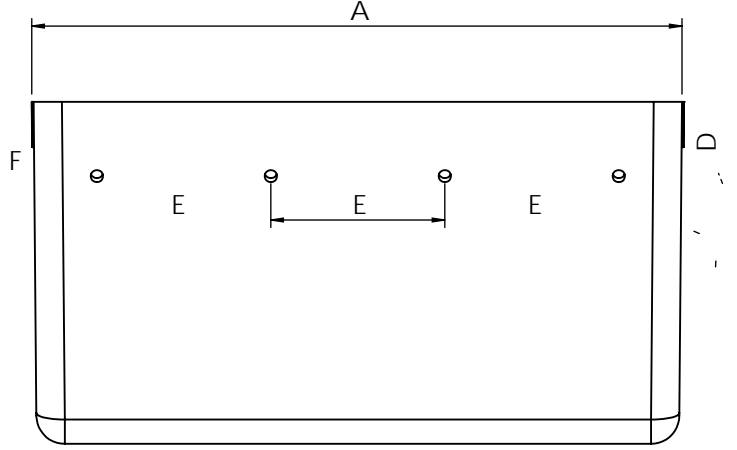
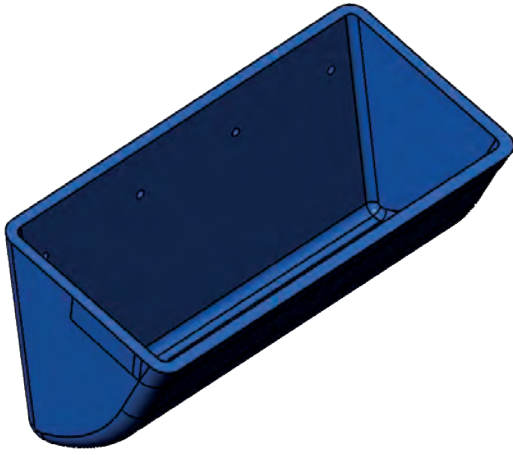

KOD	NOMİNAL ÖLÇÜ (İNÇ-MM)	A	B	C	T	D	E	F	Delik Sayısı	Z1	Z2
MCT10121	10"x6" 260x175	262	175	142	7	40	90	7	3	2,6	3,45
MCT10117	13"x7" 340x175	340	175	142	7	40	90	7	4	3,58	4,54

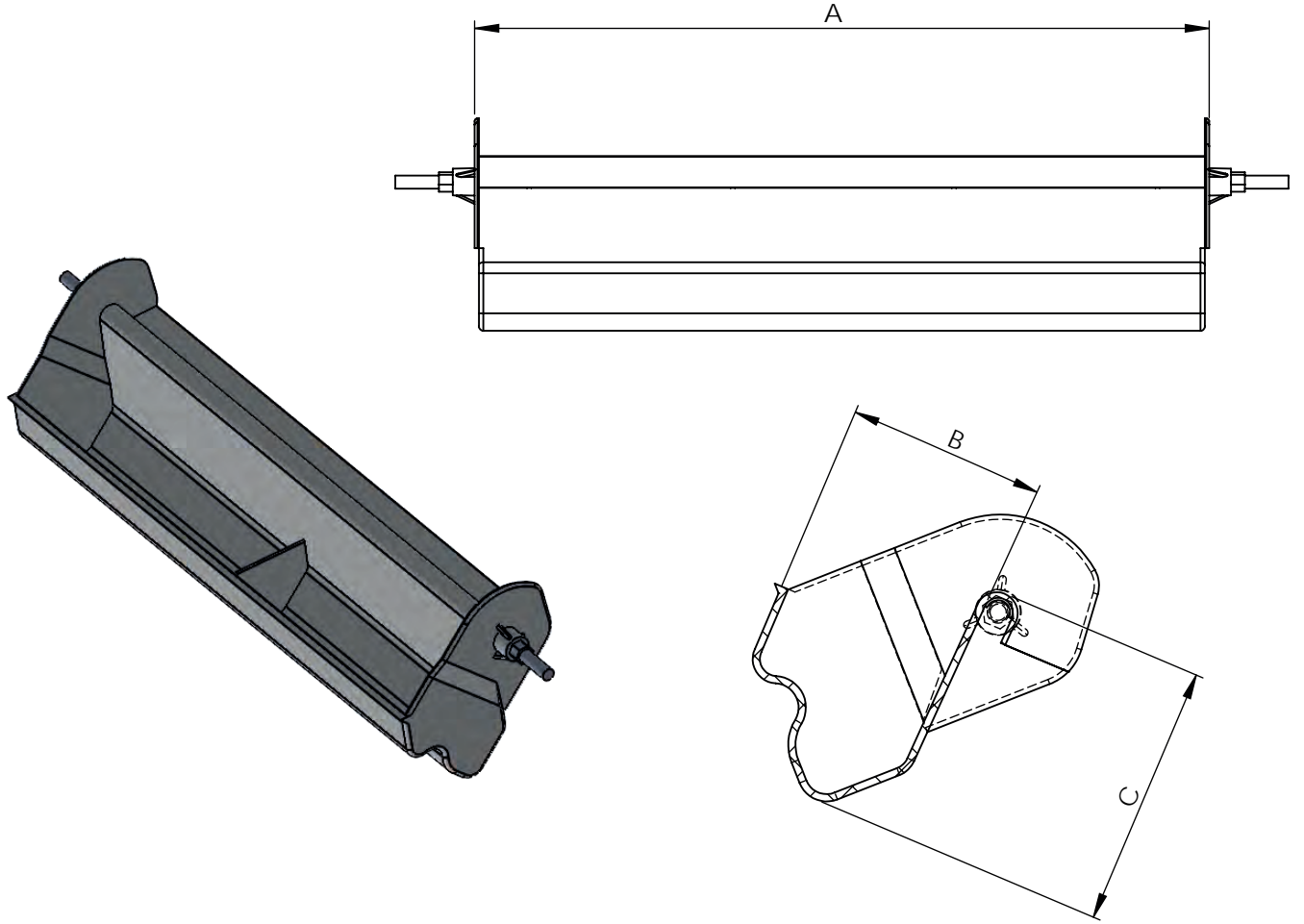

KOD	NOMİNAL ÖLÇÜ (MM)	A	B	C
MCT10154	200 - SOMUNLU	200	*	*
MCT10155	200 - MİLLİ	200	*	*
MCT10128	350 - SOMUNLU	350	*	*
MCT10122	350 - MİLLİ	350	*	*
MCT10171	500	500	*	*
MCT10151	400 - DEVİRME Lİ	400	120	82
MCT10206	520x230	520	230	115
MCT10203	600x230	600	230	115
MCT10210	630x140	630	140	180
MCT10176	310x240 - SPAGETTİ	310	240	142

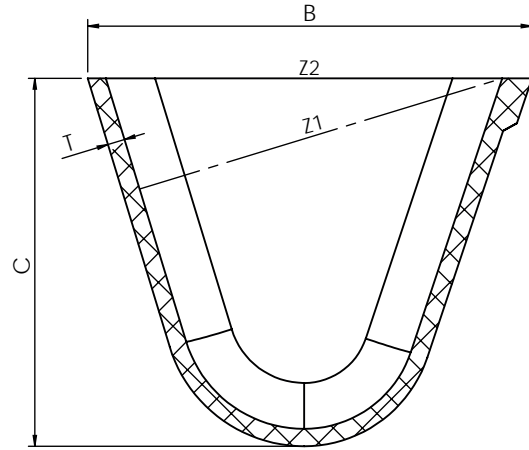
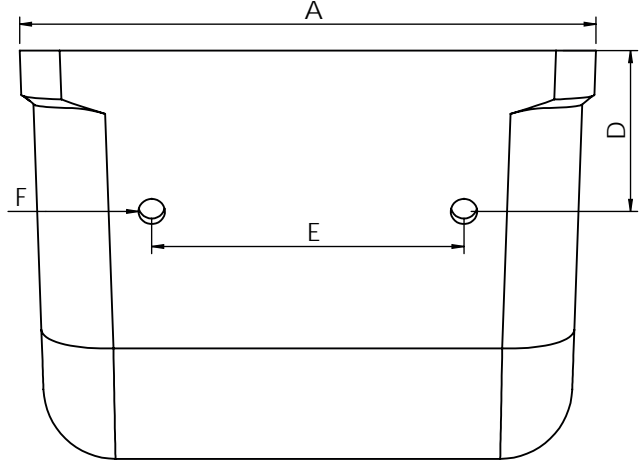

KOD	NOMİNAL ÖLÇÜ (MM)	A	B	C	T	D	E	F	Delik Sayısı	Z1	Z2
MCT10201	240x210	240	206	170	8	63	130	12	2	3,35	4,35
MCT10202	270x225	270	225	185	9	80	80	10	3	4,35	5,7

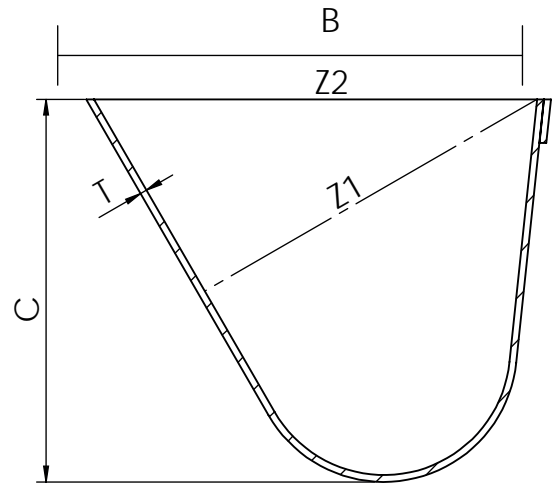
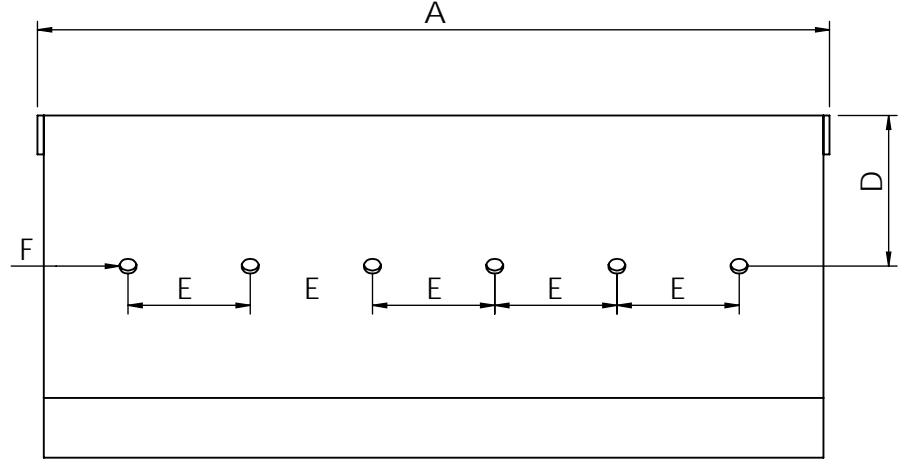
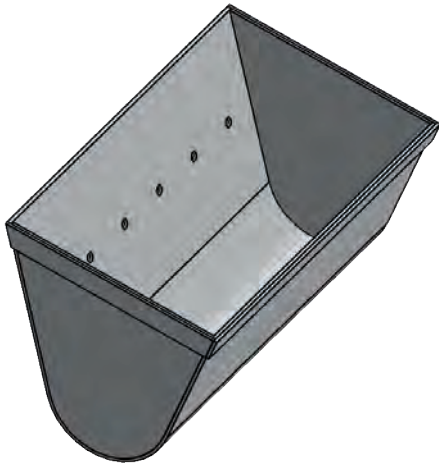

KOD	NOMİNAL ÖLÇÜ (MM)	A	B	C	T	D	E	F	Delik Sayısı	Z1	Z2
MCT10211	250x140	250	140	115	1,5	45	78	9	3	2,3	2,5
MCT10178	300x180	300	180	135	5	45	103	8	3	3,8	4,2
MCT10212	300x180	300	180	135	2	45	103	8	3	3,8	4,2
MCT10213	370x200	370	200	160	5	75	90	10	4	5	6,85
MCT10188	650x340	648	340	280	5	135,5	100	14	5	*	*

KONVEYÖR PALET

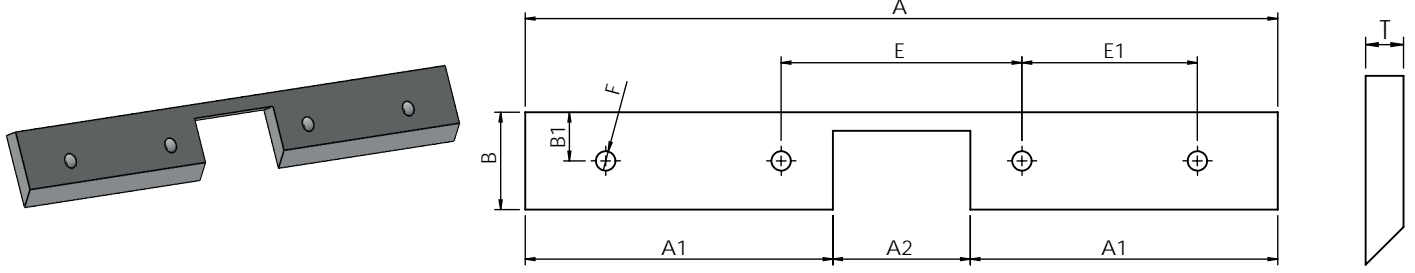

KOD	NOMİNAL ÖLÇÜ (MM)	A	A1	A2	B	B1	T	E	E1	F	Delik Sayısı
MCT10164	130x50 SAĞ-SOL	130	*	*	50	20	10	53	*	10	2
MCT10100	155x40	155	*	*	40	*	10	*	*	*	*
MCT10101	155x40	155	*	*	40	*	10	*	*	*	*
MCT10098	160x40	160	*	*	40	24	10	95	*	9,5	2
MCT10219	160x60	160	50	60	60	27	10	94,6	*	9	2
MCT10129	165x50	165	40	85	50	36,75	10	128	*	9,5	2
MCT10186	165x65	165	42	79	65	48,5	9	99	*	9,5	2
MCT10099	195x40	195	*	*	40	*	10	*	*	*	*
MCT10133	210x50	210	73	65	50	25	10	88	38	10	4
MCT10167	210x70	210	62,5	85	70	44	10	98	*	10	2
MCT10190	212x67	212	*	*	67	*	9	*	*	*	*
MCT10139	215x50	215	83	50	50	30	10	73	32	9	4
MCT10108	215x60	215	75	65	60	25	10	125	*	8,5	2
MCT10130	216x50	216	65,5	85	50	13,25	10	128	*	9,5	2
MCT10102	240x40	242	78,5	85	38	15	10	131	*	9	2
MCT10107	250x60	250	90	65	60	30	10	100	55	10	4
MCT10116	260x70	260	100	60	70	20	10	115	40	9	4
MCT10116-1	260x70	260	100	60	70	35	10	115	40	9	4
MCT10115	280x70	280	110	60	70	25	10	185	*	9	2
MCT10134	285x50	285	112	60	50	10	25	108	56	10	4
MCT10189	285x65	285	81,25	122,5	65	23	9	177,5	*	10,5	2
MCT10140	290x50	290	110	70	50	26	10	110	55	9	4
MCT10140-1	290x50	290	110	70	50	26	10	110	65	9	4
MCT10106	315x60	315	125	65	60	25	10	142	50	9	4
MCT10106-1	315x60	315	125	65	60	18	10	100	30	9	4
MCT10197	320x80	320	100	120	80	25	10	180	*	8,5	2
MCT10135	335x50	335	137	60	50	25	10	108	55	10	4
MCT10156	350x50	350	144,75	60,5	50	25	10	108	55	10	4
MCT10195	380x70	380	147,5	85	70	20	10	180	60	9	4
MCT10136	385x50	385	162,75	60,5	50	25	10	125	90	10,5	4
MCT10123	400x65	400	167,5	65	65	20	10	125	30	10	4
MCT10198	405x50	405	172	60	50	24	8	124	90	10	4
MCT10166	430x70	430	172,5	85	70	20	10	180	60	9	4
MCT10165	520x80	520	217,7	85	80	35	10	180	60	9	6
MCT10220	560x60	560	247,5	65	60	28,3	10	140	80	6	6
MCT10147	640x70	640	275,5	89	70	34	10	148	90	10	6

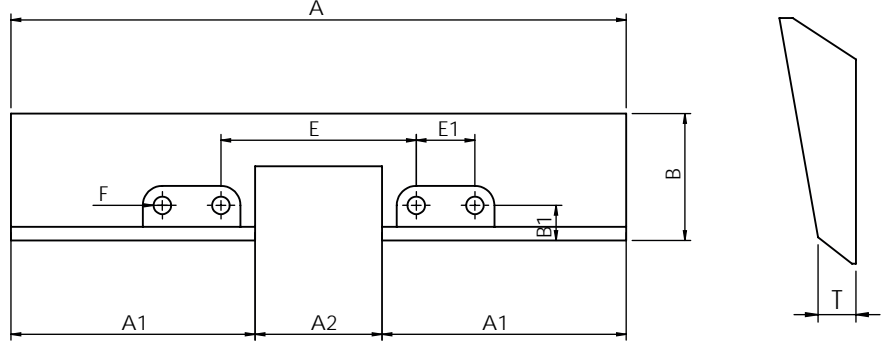
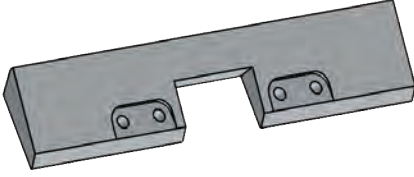

KOD	NOMİNAL ÖLÇÜ (MM)	A	A1	A2	B	B1	T	E	E1	F	Delik Sayısı
MCT10114	ZK 50 - 180x55	180	65	50	55	13	AÇILI	100	*	9	2
MCT10113	ZK 100 - 215x65	215	75	65	65	18	AÇILI	100	30	9	4
MCT10112	ZK 120 - 265x65	265	100	65	65	18	AÇILI	100	30	9	4
MCT10111	ZK 150 - 315x65	315	125	65	65	18	AÇILI	100	50	9	4
MCT10110	ZK 200 - 415x65	415	175	65	65	23	AÇILI	100	30	9	4
MCT10109	ZK 300 - 440x75	440	170	100	75	25	AÇILI	150	40	6	4
MCT10137	ZK 305 - 285x50	285	113	60,5	50	20	AÇILI	110	55	10,5	4

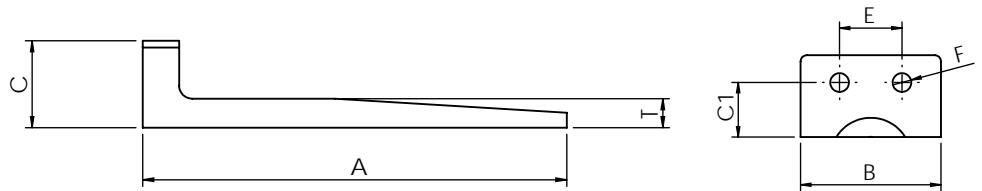
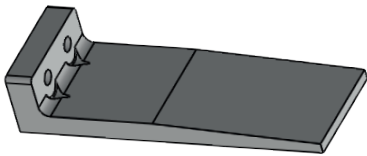

KOD	NOMİNAL ÖLÇÜ (MM)	A	A1	A2	B	C	C1	T	E	F	Delik Sayısı
MCT10207	130x45	130	*	*	45	26	18	9	20	6	2



MCT10217

KONVEYÖR DİSK



MCT10105

KONVEYÖR ZİNCİRİ PLASTİK



MCT10170

Z ELEVATÖR ZİNCİRİ METAL



MCT02051

ZİNCİR 76 MM



MCT02052

ZİNCİR 74 MM



MCT10131

ELEVATÖR BANT

DEĞİRMEN
GÖSTERGE
CAMI

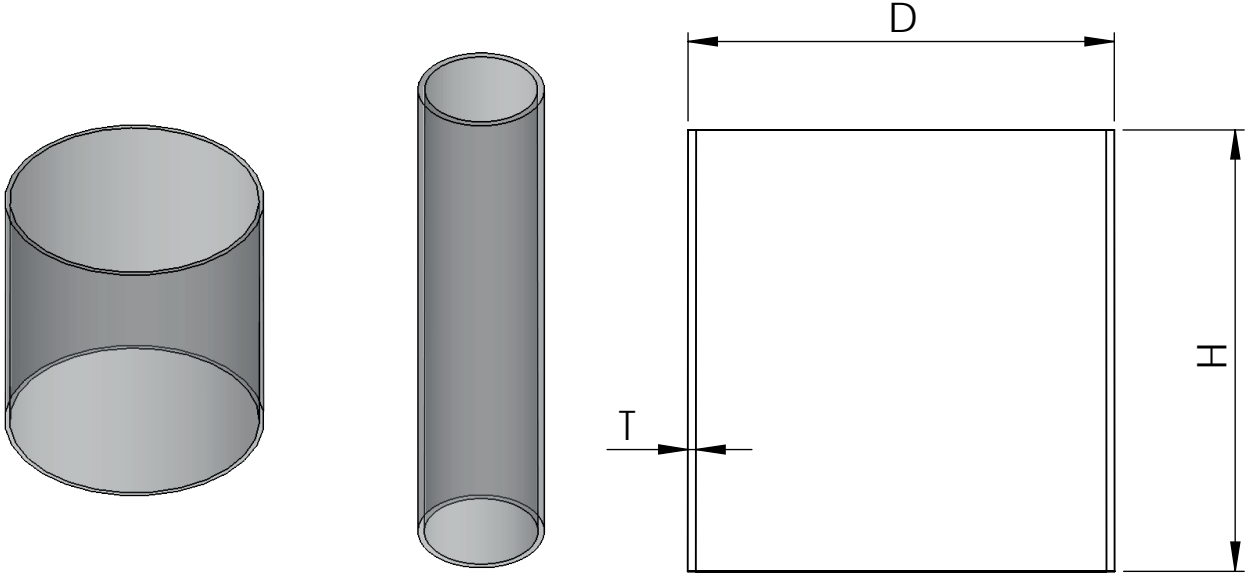

KOD	NOMİNAL ÖLÇÜ (MM)	D	H	T
MCT10193	Ø63x300	Ø63	300	3,5
MCT10194	Ø70x300	Ø70	300	3,5
MCT10191	Ø76x300	Ø76	300	3,5
MCT10192	Ø83x300	Ø83	300	3,5
MCT10204	Ø89x300	Ø89	300	3,5
MCT10205	Ø102x300	Ø102	300	3,5
MCT10208	Ø108x300	Ø108	300	3,5
MCT10209	Ø114x300	Ø114	300	3,5
MCT10185	Ø145x150	Ø145	150	3,5
MCT10196	Ø165x150	Ø165	150	3,5

BAĞLANTI ELEMENLARI

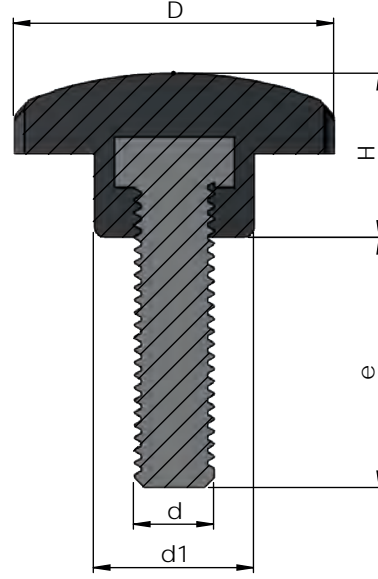
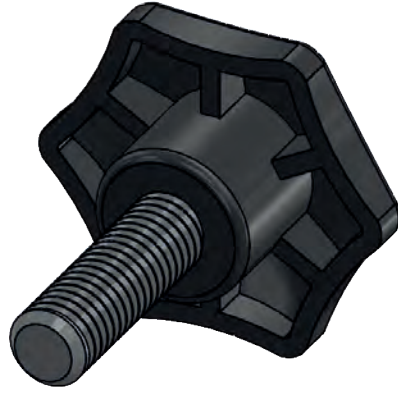

KOD	NOMİNAL ÖLÇÜ (MM)	D	H	d	e	d1
MCT10005	M5x10 VİDA	35	17	5	10	15
MCT10006	M5x15 VİDA	35	17	5	15	15
MCT10007	M5x20 VİDA	35	17	5	20	15
MCT10008	M5x25 VİDA	35	17	5	25	15
MCT10009	M5x30 VİDA	35	17	5	30	15
MCT10010	M5x40 VİDA	35	17	5	40	15
MCT10011	M5x45 VİDA	35	17	5	45	15
MCT10012	M5x50 VİDA	35	17	5	50	15
MCT10013	M5x55 VİDA	35	17	5	55	15
MCT10014	M5x60 VİDA	35	17	5	60	15
MCT10016	M6x10 VİDA	35	17	6	10	15
MCT10017	M6x15 VİDA	35	17	6	15	15
MCT10018	M6x20 VİDA	35	17	6	20	15
MCT10019	M6x25 VİDA	35	17	6	25	15
MCT10020	M6x30 VİDA	35	17	6	30	15
MCT10021	M6x35 VİDA	35	17	6	35	15
MCT10022	M6x40 VİDA	35	17	6	40	15
MCT10023	M6x45 VİDA	35	17	6	45	15
MCT10024	M6x50 VİDA	35	17	6	50	15
MCT10025	M6x55 VİDA	35	17	6	55	15
MCT10026	M6x60 VİDA	35	17	6	60	15
MCT10056	M8x10 VİDA	45	26	8	10	18
MCT10057	M8x15 VİDA	45	26	8	15	18
MCT10058	M8x20 VİDA	45	26	8	20	18
MCT10059	M8x25 VİDA	45	26	8	25	18
MCT10060	M8x30 VİDA	45	26	8	30	18
MCT10061	M8x35 VİDA	45	26	8	35	18
MCT10062	M8x40 VİDA	45	26	8	40	18
MCT10063	M8x45 VİDA	45	26	8	45	18
MCT10064	M8x50 VİDA	45	26	8	50	18
MCT10065	M8x55 VİDA	45	26	8	55	18

KOD	NOMİNAL ÖLÇÜ (MM)	D	H	d	e	d1
MCT10066	M8x60 VİDA	45	26	8	60	18
MCT10067	M8x65 VİDA	45	26	8	65	18
MCT10068	M8x70 VİDA	45	26	8	70	18
MCT10028	M10x10 VİDA	55	26	10	10	22
MCT10029	M10x15 VİDA	55	26	10	15	22
MCT10030	M10x20 VİDA	55	26	10	20	22
MCT10031	M10x25 VİDA	55	26	10	25	22
MCT10032	M10x30 VİDA	55	26	10	30	22
MCT10033	M10x35 VİDA	55	26	10	35	22
MCT10034	M10x40 VİDA	55	26	10	40	22
MCT10035	M10x45 VİDA	55	26	10	45	22
MCT10036	M10x50 VİDA	55	26	10	50	22
MCT10037	M10x55 VİDA	55	26	10	55	22
MCT10038	M10x60 VİDA	55	26	10	60	22
MCT10039	M10x65 VİDA	55	26	10	65	22
MCT10040	M10x70 VİDA	55	26	10	70	22
MCT10042	M12x10 VİDA	65	32	12	10	26
MCT10043	M12x15 VİDA	65	32	12	15	26
MCT10044	M12x20 VİDA	65	32	12	20	26
MCT10045	M12x25 VİDA	65	32	12	25	26
MCT10046	M12x30 VİDA	65	32	12	30	26
MCT10047	M12x35 VİDA	65	32	12	35	26
MCT10048	M12x40 VİDA	65	32	12	40	26
MCT10049	M12x45 VİDA	65	32	12	45	26
MCT10050	M12x50 VİDA	65	32	12	50	26
MCT10051	M12x55 VİDA	65	32	12	55	26
MCT10052	M12x60 VİDA	65	32	12	60	26
MCT10053	M12x65 VİDA	65	32	12	65	26
MCT10054	M12x70 VİDA	65	32	12	70	26
MCT10073	M6x20/ 5x30 VİDA-YUVARLAK BAŞLI	20	7	5/6	DEĞİŞKEN	12
MCT10074	M6x15 VİDA	26	7	6	DEĞİŞKEN	13

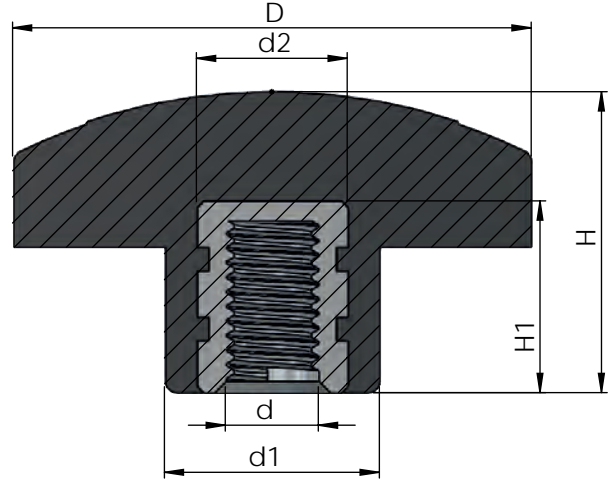
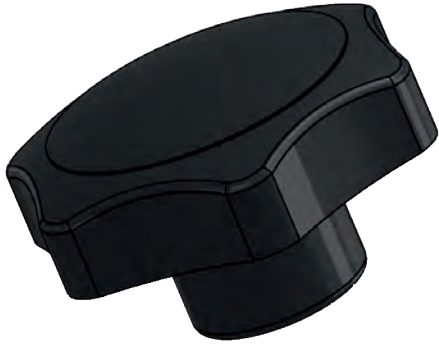

KOD	NOMİNAL ÖLÇÜ (MM)	DT	B	C	T	D	E	E
MCT10015	M5 SOMUN	35	5	15	6	17	8	13
MCT10027	M6 SOMUN	35	6	15	6	17	8	13
MCT10069	M8 SOMUN	45	8	18	6	26	12	16,5
MCT10041	M10 SOMUN	55	10	22	6,5	26	14	18
MCT10055	M12 SOMUN	65	12	26	6	32	14	18
MCT06100	M16 KELEBEK SOMUN - SONSUZ	67	16	30	8	40	*	*
MCT10071	M12 MM DEMİR KELEBEK SOMUN Ø60	65	12	26	6	32	*	*
MCT10072	M16 MM DEMİR KELEBEK SOMUN Ø60	65	16	26	9	32	*	*
MCT10199	M6 YUVARLAK SOMUN	28	6	16	8	30	*	*
MCT10200	M8 YUVARLAK SOMUN	28	8	16	6,5	30	*	*

TUTMA-ÇEVİRME KOLLARI



MCT10075

LÜKS KAPAK KOLU 100 MM



MCT10076

LÜKS KAPAK KOLU 130 MM



MCT18031

LÜKS KAPAK KOLU OVAL



MCT10077

MAKİNA TUTMA KOLU 140 MM



MCT06041

ÇEVİRME KOLU 80 MM



MCT17003

ÇEVİRME KOLU 110 MM



MCT10001

ÇEVİRME KOLU Ø100 MM



MCT10002

ÇEVİRME KOLU Ø130 MM



MCT10004

ÇEVİRME KOLU Ø165 MM



MCT10003

ÇEVİRME KOLU Ø190 MM



MCT02034

YENİ TİP KOL



MCT02032

GERDİRME KOLU YUVARLAK



MCT02033

GERDİRME KOLU 6 KÖŞELİ

TAPETEN



MCT10145

DİP SİYİRİCİ



MCT10146

FİRÇALI TAPETEN



MCT10126

DAMLA TAPETEN



MCT10214

STAR FİRÇALI TAPETEN



MCT10215

STAR DAMLA TAPETEN

**DEĞİRMEN
MAKİNALARI
EKİPMANLARI**



MCT10080

MENTEŞE 40 MM



MCT10079

MENTEŞE 50 MM



MCT21021

MENTEŞE 60 MM



MCT21085

MENTEŞE 80 MM



MCT10184

ZİNCİR MUHAFAZA TAKIM (5/8-20 DİŞ)



MCT10187

BURÇ 50x20,5x99 MM



MCT10168

BURÇ 50x18x31 MM



MCT18003

KAYNAK KOL BAŞLIĞI



MCT18026

DOLAP KİLİDİ



MCT10082

DEĞİRMEN VAKUM LASTİK BÜYÜK



MCT10083

DEĞİRMEN VAKUM LASTİK KÜÇÜK



MCT10158

DEĞİRMEN PATLAÇ BÜYÜK



MCT10159

DEĞİRMEN PATLAÇ KÜÇÜK



MCT10160

DEĞİRMEN PATLAÇ PLS. PUL 6 MM



MCT10161

DEĞİRMEN PATLAÇ PLS. PUL 8 MM



MCT10105

KONVEYÖR ZİNCİRİ PLASTİK



MCT10170

Z ELEVATÖR ZİNCİRİ METAL



MCT17071

TAŞIYICI PALET



MCT17072

YARASA BANT



MCT17082

MODÜLER BANT



MCT10131

ELEVATÖR BANT



MCT10132

KOKO CİVATA M6/M8/M10/M12



MCT10138

270 İÇ BORU FD DÖNER PLS



MCT10148

200 İÇ BORU FD DÖNER PLS TİP 3



MCT10149

200 İÇ BORU FD DÖNER PLS TİP 2



📍 Büyükkayacık Osb Sarıççek Sk.
No:6 Selçuklu/Konya

☎ +90 332 239 16 00 (pbx)

🌐 /mucitplastik

🌐 www.mucit.com

✉ bilgi@mucit.com
sales@mucit.com